

5–6K Interface Board

The 5-6K Interface Board provides a complete system development platform using evaluation modules from the Data Acquisition Products Group. This board passes signals from TMS320C5000™ and TMS320C6000™ DSK platforms featuring the 80-pin daughtercard connectors defined in the TMS320 Cross-Platform Daughtercard Interface ([SPRA711](#)), to a variety of analog-to-digital and digital-to-analog converters. When combined with sensor or amplifier boards, it can provide a complete data acquisition system for a variety of applications.

Contents

1	Introduction	1
2	Power Connections to the Interface Card	2
3	Serial EVM Sites	3
4	Parallel EVM Site	5
5	5-6K Interface Bill of Material	8
6	Related Documentation from Texas Instruments	9
7	5-6K Interface Board Assembly and Schematics	9

List of Tables

1	External Power Connections	2
2	Signal Conditioning I/O Connections	2
3	Signal Conditioning Power Connections—JP1, JP2, JP3, and JP4	3
4	Digital I/O Connections—J15 and J16	3
5	EVM Power Connections—JP5 and JP6	4
6	EVM Analog I/O Connections—J10 and J12	4
7	Parallel Control Connections	5
8	Parallel EVM Clocking Options via J14	6
9	External Interrupt Source via J13	6
10	Parallel Control Connections	7
11	Bill of Material	8

1 Introduction

The 5-6K Interface Board provides data converter customers with flexibility for the evaluation of data acquisition products from Texas Instruments. The Interface Board maintains a compatible interface with the TMS320™ DSP family according to the guidelines set forth in the TMS320 Cross-Platform Daughtercard Specification ([SPRA711](#)). Signal names and references to the multichannel buffered serial port (McBSP) found throughout this document are common to those found in the [SPRA711](#) document.

The Interface Board consists of two signal conditioning sites, two serial EVM sites, and a parallel EVM site. Regardless of the interface type, all EVMs compatible with the 5-6K Interface Board have a standard analog interface and standard power connector. Three-position screw terminals J1 and J2 and two-position screw terminals J6, J8, J9, and J11 provide access to a common power bus routed to all sites.

2 Power Connections to the Interface Card

The screw terminals along the bottom edge of the Interface Board give access to the common power bus. Three-port terminals J1 and J2 provide analog power. Two-port terminals J6, J8, J9, and J11 provide the digital voltages. Two jumpers, W2 and W3, located on the Interface Board give the user the option of using DSK +5 V and +3.3 V for the digital power. Analog power must be supplied from an external source. [Table 1](#) shows the typical external power connections.

Table 1. External Power Connections

Screw Terminal	Applied Voltage	Typical Function
J1	\pm VA (\pm 18 V Max)	Analog Voltage—provides analog power for signal conditioning, sensor boards, amplifiers, etc.
J2	\pm 5V (\pm 5.5 V Max)	Analog Voltage—provides analog power for signal conditioning, sensor boards, amplifiers, etc.
J6	+5 (5.5 V Max)	Digital Voltage—power to digital logic - ADCs, DACs, etc.
J8	+VD (undefined)	Digital Voltage—Reserved for future use
J9	+1.8 V (2.3 V Max)	Digital Voltage—core logic voltage for Codecs etc.
J11	+3.3 V (3.7 V Max)	Digital Voltage—power to digital logic – ADCs, DACs, etc.

2.1 Signal Conditioning Sites

The signal conditioning sites provide a 20-pin analog I/O header and a 6-pin header for the analog power supply connections.

2.1.1 Signal Conditioning Analog I/O Connection

The analog I/O connectors, J3 and J4, provide up to eight single-ended or four differential channels to/from the data converter. External reference voltages can also be applied to the data converter through the analog I/O connector. Because the reference requirements vary by converter type, no restrictions are placed on the input voltage levels. Be sure to check the documentation for the EVM before applying any input signals. Single- and dual-channel converters leave the unused pins open. [Table 2](#) shows the standard analog connector pinout. See [Section 3.3](#) for details on applying differential signals.

Table 2. Signal Conditioning I/O Connections

Signal	Pin Number		Signal
A0-	1	2	A0
A1-	3	4	A1
A2-	5	6	A2
A3-	7	8	A3
AGND	9	10	A4
AGND	11	12	A5
AGND	13	14	A6
VCOM	15	16	A7
AGND	17	18	REF-
AGND	19	20	REF+

The 20-pin headers located beside JP1 and JP2 provide stability for the signal conditioning boards—no signals are routed to or from these connectors. These connectors are labeled Analog 1 and Analog 2 in the assembly drawing found in [Section 7](#).

2.2 Signal Conditioning Power Connector

The Interface Board provides a common power bus to both signal conditioning sites. The power connector used on the Interface Board is a 6-pin male header. Four power connectors JP1, JP2, JP3, and JP4 are provided—each with the same pinout. This allows an analog-to-digital (ADC) converter to use the same signal conditioning board as a digital-to-analog (DAC) converter, simply by rotating the signal conditioning board 180 degrees.

Table 3 shows the power connector voltages supplied to the signal conditioning module.

Table 3. Signal Conditioning Power Connections—JP1, JP2, JP3, and JP4

Signal	Pin Number		Signal
+VA	1	2	-VA
+5VA	3	4	-5VA
AGND	5	6	AGND

3 Serial EVM Sites

The serial interface consists of two digital I/O connectors (J15 and J16), two power connectors (JP5 and JP6), and two analog I/O connectors (J10 and J12). The analog I/O connectors are configured as pass through connections from/to the signal conditioning sites. See Section 2.1 for more information.

3.1 Serial Digital I/O Connections

The serial site digital I/O connectors are 20-pin headers that provide access to the serial interface signals defined in the TMS320 Cross-Platform Daughtercard Specification ([SPRA711](#)). These signals are based on the multichannel buffered serial port (McBSP) interface found on most Texas Instruments DSPs.

Table 4 shows the standard serial connector pinout.

Table 4. Digital I/O Connections—J15 and J16

Signal ⁽¹⁾		Pin Number		Signal ⁽¹⁾	
Site 1 (J15)	Site 2 (J16)			Site 1 (J15)	Site 2 (J16)
DC_CNTLb	DC_CNTLa	1	2	TP Access	TP Access
DC_CLKXb	DC_CLKXa	3	4	DGND	DGND
DC_CLKRb	DC_CLKRa	5	6	TP Access	TP Access
DC_FSXb	DC_FSXa	7	8	TP Access	TP Access
DC_FSRb	DC_FSRa	9	10	DGND	DGND
DC_DXb	DC_DXa	11	12	TP Access	TP Access
DC_DRb	DC_DRa	13	14	TP Access	TP Access
DC_INTc	DC_INTa	15	16	TP Access	TP Access
DC_TOUTb	DC_TOUTa	17	18	DGND	DCND
TP Access	TP Access	19	20	TP Access	TP Access

⁽¹⁾ Revision B boards include 470-Ω pulldown resistors at all points listed as TP Access via 6-position slide switches SW1 and SW2.

3.2 Chip Select, Frame Sync and Interrupt Options

DC_CNTLa and DC_CNTLb are routed directly to pin 1 of the Digital I/O connectors (J15 and J16 respectively) on Revision A Interface Boards. Revision B interface boards include jumpers W12 and W13 which apply the DC_CNTLx signal (default) or digital ground (shunt pins 2-3) to pin 1 of the digital I/O connectors.

Revision B interface boards also include jumpers W10 and W11 which allow the user to apply the FSX signal (default) or DC_CNTLx signal (shunt pins 2-3) to pin 7 of the digital I/O connectors. W10 controls the application of DC_FSXa or DC_CNTLa on J15, while W11 controls the application of DC_FSXb or DC_CNTLb on J16.

Jumpers W8 and W9 allow the signals applied to DC_INTa or DC_INTc to be directly sourced from the data-converter EVM when the shunts are installed on pins 1-2 (default). Moving the shunt on W8 to pins 2-3 sends the EVM interrupt signal through a single-gate inverter (U5) before being sent to DC-INTa on the DSK. W9 controls the polarity of the signal applied to DC-INTc via U6.

3.3 EVM Power Connector

The Interface Board provides a common power bus to both serial sites. The power connector used on the Interface Board is a 10-pin male header. Two power connectors JP5 and JP6 are provided—each with the same pinout. JP5 services serial Site 2, while JP6 services serial Site 1. [Table 5](#) shows the power-connector voltages supplied to the EVM.

Table 5. EVM Power Connections—JP5 and JP6

Signal	Pin Number		Signal
+VA	1	2	-VA
+5VA	3	4	-5VA
DGND	5	6	AGND
+1.8VD	7	8	VD1
+3.3VD	9	10	+5VD

3.4 EVM Analog I/O Connector

As mentioned previously, the analog I/O connectors act as pass-through connectors to the signal conditioning sites. [Table 6](#) shows the analog I/O connections to the serial and parallel EVM sites.

Table 6. EVM Analog I/O Connections—J10 and J12⁽¹⁾

Signal	Pin Number		Signal
A0-	1	2	A0
A1-	3	4	A1
A2-	5	6	A2
A3-	7	8	A3
AGND	9	10	A4
AGND	11	12	A5
AGND	13	14	A6
VCOM	15	16	A7
AGND	17	18	REF-
AGND	19	20	REF+

⁽¹⁾ J10 and J12 are also used for the parallel EVM site.

When applying differential signals to a data converter EVM, the signal pairs may be applied between pin pairs 1-2, 3-4, 5-6, and 7-8, or pin pairs 2-4, 6-8, 10-12, and 14-16. The pin assignment for the signal pair is determined by the EVM being used. See the specific EVM user's guide for implementation details.

4 Parallel EVM Site

The parallel interface consists of a 48-pin header (J17), which provides access to up to 24 parallel data bits and a 20-pin parallel control header (J18). The parallel control header provides four multiplexed address lines, configurable read and write strobes, configurable interrupts, and chip-select and clock signals. Analog I/O and power is also provided.

4.1 Parallel Analog I/O and Power Connections

The parallel site uses the same analog I/O and power connections described in the serial interface section of this manual. Typically, a parallel-ADC EVM uses the analog interface connector located at J10 and the power connector located at JP5. See [Section 3](#) for pinout details. A parallel-DAC EVM typically uses the analog interface connector J12, presenting the opportunity to stack certain EVMs.

4.2 Parallel Control Connector—J18

The parallel control connector feeds chip-select, read, write, and address lines to the parallel EVMs. The address decoding for most parallel EVMs is done on the EVM card itself, allowing the possibility of stacking several cards together. [Table 7](#) shows the typical signals found on parallel interface EVMs, designed to be used with the 5–6K Interface Board

Table 7. Parallel Control Connections

Signal	Pin Number		Signal
DC_CSx	1	2	DGND
\overline{WR} (R/W)	3	4	DGND
\overline{RD}	5	6	DGND
EVM_A0	7	8	DGND
EVM_A1	9	10	DGND
EVM_A2	11	12	DGND
EVM_A3	13	14	DGND
GPIO (SPARE–NC)	15	16	DGND
TOUTa	17	18	DGND
INT	19	20	DGND

DC_CSx is defined in the TMS320 Cross-Platform Daughtercard Specification. This signal is intended to act as a chip-select to the EVM, not necessarily the actual data converter being evaluated. Carefully read the documentation that came with your EVM for details on how this signal is used. Revision-B Interface boards include jumper W16 which applies DC_CSa (default) or DC_CSb (shunt pins 2-3) to J18 pin 1.

The write and read strobes can be controlled through jumpers W4 and W5 on the Interface Card. With W4 and W5 in their default positions (shunt on pins 2-3), WR and RD are defined as in the TMS320 Cross-Platform Daughtercard Specification. With the shunts on W4 and W5 in positions 1-2, combination logic located on the interface card can provide a simple strobing arrangement which may be useful with the TMS320C5402 DSK.

The EVM address lines EVM_A0 through EVM_A3 are fed from a four-bit 2:1 bus switch, U1. Typically, this provides access to DSP address lines A2..A5, or A14..A17. A shunt on W1 (default) applies the DSK address lines A2..A4 to the parallel control connector; removing the shunt from W1 applies address lines A14..A17. The actual address lines vary depending on the DSK used; see your DSK documentation for the exact address locations.

The interface card provides four options for a clock source to the parallel EVM interface with use of a 2-mm shunt on J14.

Table 8. Parallel EVM Clocking Options via J14

Shunt on Pins	Clock Source
1–2	DC_TOUTa
3–4	DC_TOUTa
5–6	DC_CLKXa
7–8	DC_CLKXb

The interface card provides two options for an external interrupt source to the DSP with use of a 2-mm shunt on J15.

Table 9. External Interrupt Source via J13⁽¹⁾

Shunt on Pins	Connects To:	
	Rev A PWB	Rev B PWB
1–2	DC_INTa	DC_INTb
3–4	DC_INTb	DC_INTb
5–6	DC_INTc	DC_INTd
7–8	DC_INTd	DC_INTd

⁽¹⁾ External interrupts shown in this table are based on the TMS320C6711 DSK.

4.3 Inverted Interrupts

Jumper W7 on the 5–6K Interface Board revision B expands the interrupt capabilities of certain data-converter EVMs. W7 controls the signal applied to J13 via single-gate inverter U7. When a shunt is installed on W7-pins 1-2 (default), the interrupt signal is applied directly to J13. Installing the shunt on W7-pins 2-3 provides an interrupt inverted signal to J13 via U7.

4.4 Parallel Data Bus Connector—J17

The parallel data connector used on the Interface Card is a 48-pin male header. Typical parallel EVMs have a data bus that is a minimum of 16 bits wide and a maximum of 24 bits. Bus expansion is done in 4-bit increments. Data is aligned LSB to LSB.

Table 10 shows the parallel data bus connections.

Table 10. Parallel Control Connections

Signal	Pin Number		Signal
D0	1	2	DGND
D1	3	4	DGND
D2	5	6	DGND
D3	7	8	DGND
D4	9	10	DGND
D5	11	12	DGND
D6	13	14	DGND
D7	15	16	DGND
D8	17	18	DGND
D9	19	20	DGND
D10	21	22	DGND
D11	23	24	DGND
D12	25	26	DGND
D13	27	28	DGND
D14	29	30	DGND
D15	31	32	DGND
D16	33	34	DGND
D17	35	36	DGND
D18	37	38	DGND
D19	39	40	DGND
D20	41	42	DGND
D21	43	44	DGND
D22	45	46	DGND
D23	47	48	DGND

5 5-6K Interface Bill of Material
Table 11. Bill of Material

Item	Qty	Designators	Description	Manufacturer	Mfg. Part Number
1	1	N/A	Printed Wiring Board	Texas Instruments	
2	6	C1 C2 C3 C4 C5 C6	0.1uF, 0805, Ceramic, X7R, 50V, 10%	Panasonic	ECJ-2YB1H104K
3	2	J1 J2	3 Terminal Screw Connector	OST	ED1515
4	4	J3 J4 ANALOG 1&2	10 Pin, Dual Row, TH Header (20 Pos.)	Samtec	TSW-110-07-L-D
5	4	J6 J8 J9 J11	2 Terminal Screw Connector	OST	ED1514
6	5	J10 J12 J15 J16 J18	10 Pin, Dual Row, SMT Header (20 Pos.)	Samtec	TSM-110-01-T-DV-P
7	2	J13 J14	4 Pin, Dual Row, 2mm Header (8 Pos.)	Samtec	TMM-104-03-T-D
8	1	J17	24 Pin, Dual Row, SMT Header (48 Pos.)	Samtec	TSM-124-01-T-DV-P
9	2	J19 J20	80 Pin SMT connector	Samtec	TFM-140-32-S-D-LC
10	4	JP1 JP2 JP3 JP4	3 Pin, Dual Row, TH Header (6 Pos.)	Samtec	TSW-103-07-L-D
11	2	JP5 JP6	5 Pin, Dual Row, SMT Header (10 Pos.)	Samtec	TSM-105-01-T-DV-P
12	2	R1 R3	10K ohm, 0805, .1W Resistor	Yageo America	9C08052A1002JLHFT
13	1	R2	49.9 ohm, 0805, 1%, .1W Resistor	Yageo America	9C08052A49R9FKHFT
14	2	R5 R7	470 ohm, 8 Element Array	CTS	742C163471JTR
15	2	SW1 SW2	CTS 219 Series SMT SPST Switch	CTS	219-6LPST
16	4	TP1 TP2 CLKs DGND	Red Test Point Loop	Keystone	5000
17	1	U1	SN74CBT3257	TI	SN74CBT3257PWR
18	4	U2 U5 U6 U7	1G04	TI	SN74AHC1G04DBVR
19	2	U3 U4	1G32	TI	SN74AHC1G32DBVR
20	1	W1	2 Pin Header - .1"centers	Samtec	TSW-102-07-L-S
21	3	W2 W3 W6	3 Pin Header - .1" centers	Samtec	TSW-103-07-L-S
22	9	W4 W5 W7 W8 W9 W10 W11 W12 W13	3 Pin 2mm Header	Samtec	TMM-103-03-T-S

5-6K Interface Board (Rev. B) - Top View

Signal Conditioning Site 1

Analog I/O = J4
Power = JP2 or JP4

Serial Site 1

Analog I/O = J10
Digital I/O = J16
Power = JP6

Analog 1

Analog 2

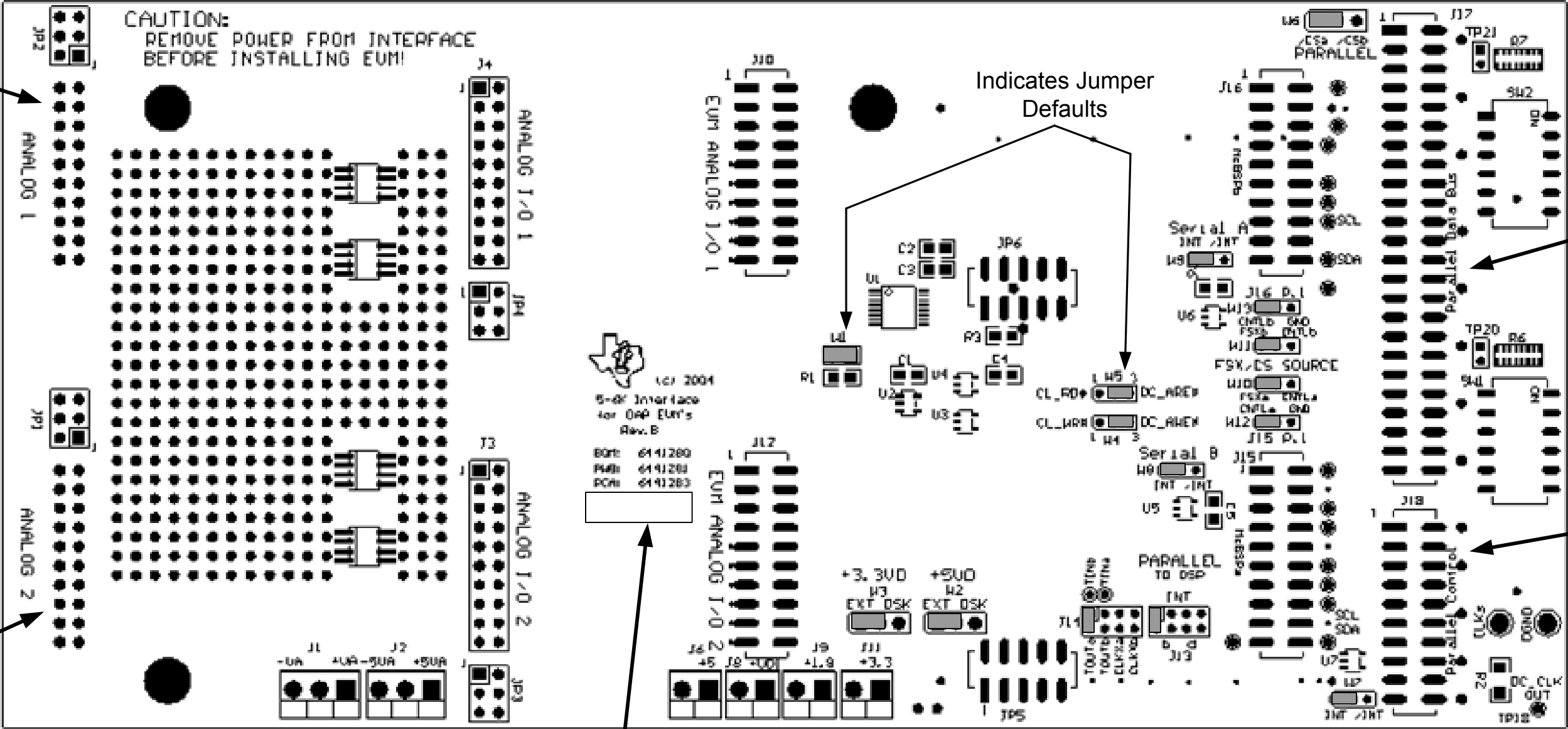

Signal Conditioning Site 2

Analog I/O = J3
Power = JP1 or JP3

Assy. Revision Label

Serial Site 2

Analog I/O = J12
Digital I/O = J15
Power = JP5

Parallel Interface

Analog I/O = J10 (ADC's) or J12 (DAC's)
Parallel Data Bus = J17
Parallel Control = J18
Power = JP5

Parallel Data Bus

Parallel Control

5-6K Interface Board - Bottom View

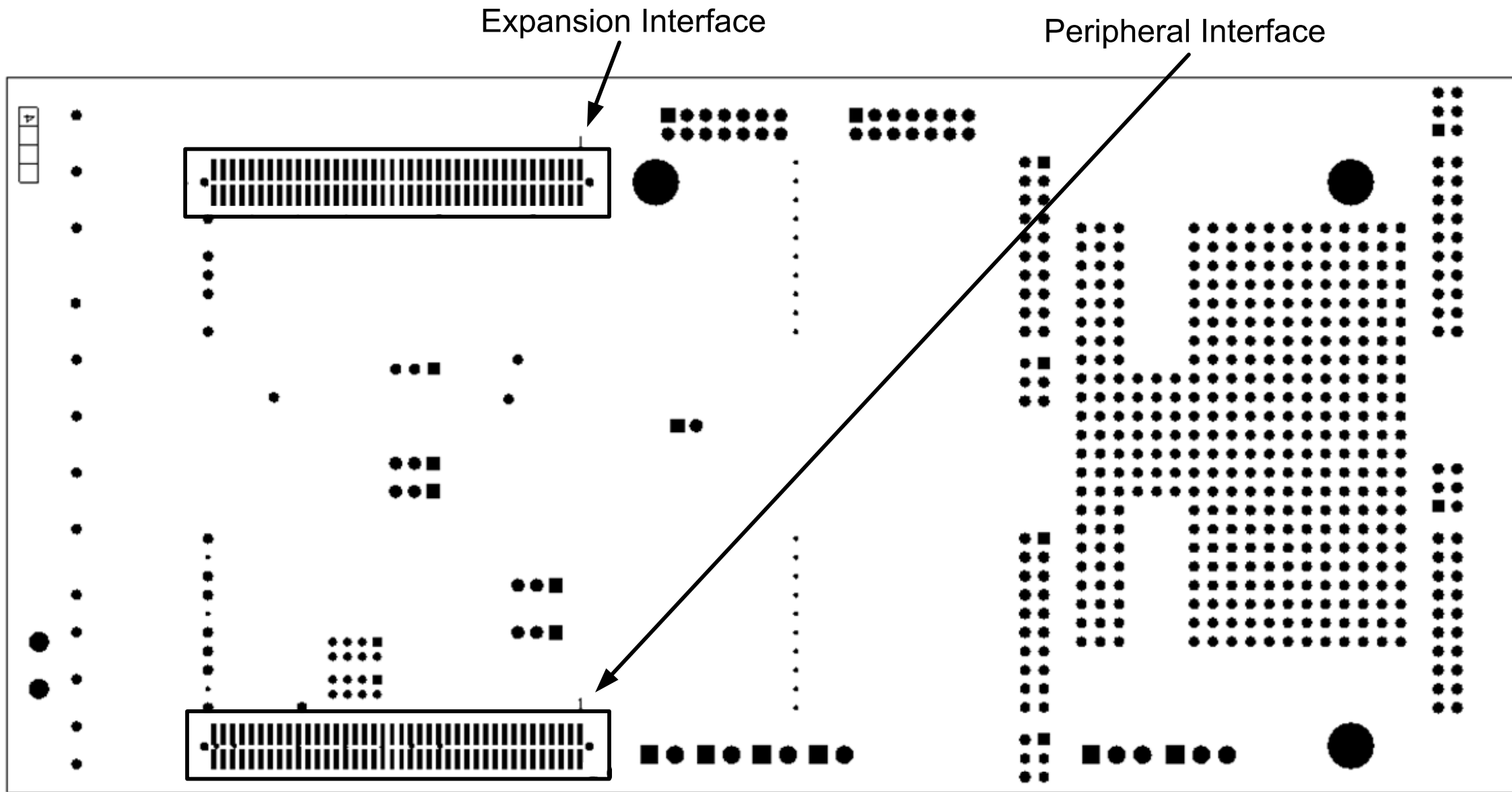

5-6K Interface Board

C5/6000 DSK Board

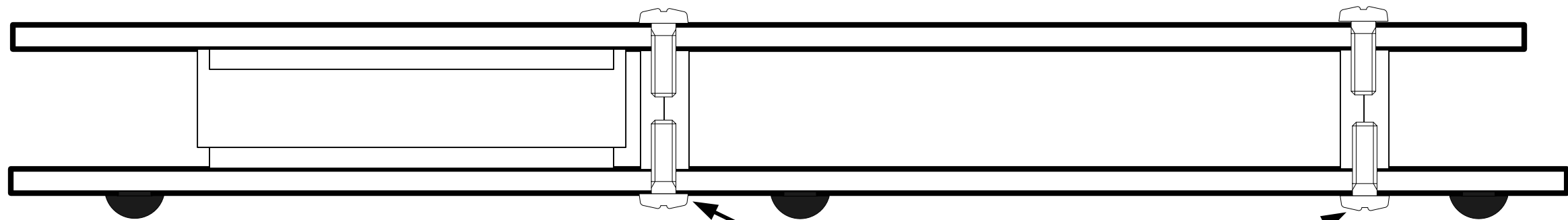

#4-40 x 1/4 inch - 3 places
(optional)

Serial EVM Digital Interface

Note: GPIO Test Points to Switch - See Page 2

Revision History		
REV	ECN Number	Approved
A	Initial Release	TH
B	Design Enhancements	04/02/04

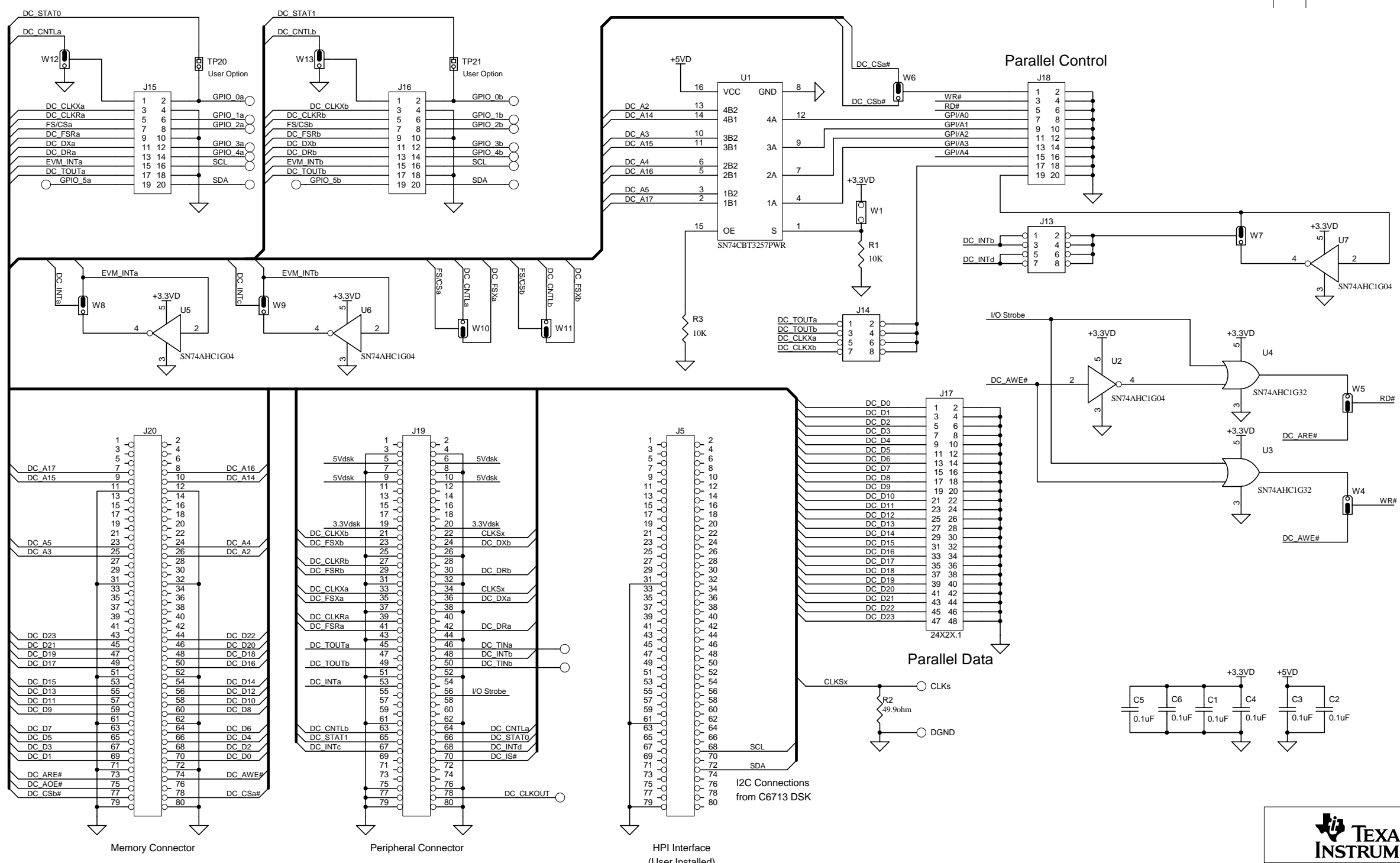

SPRA711 Daughtercard Interface



12500 TI Boulevard, Dallas, Texas 75243

Title: 5-6K Interface Board Schematic			
Engineer: Tom Hendrick	SIZE: B	DATE: 24-May-2006	REV: B
Drawn By: Tom Hendrick	FILE: EDGE #6441282	SHEET: 1	OF: 2

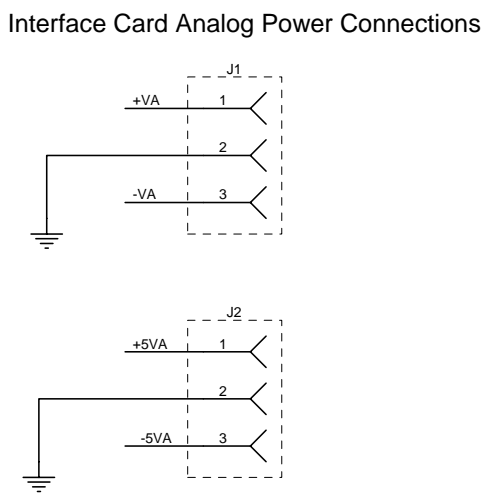
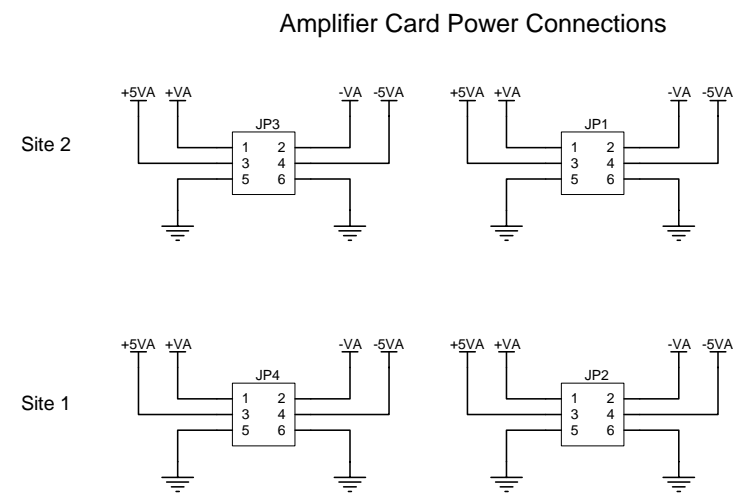
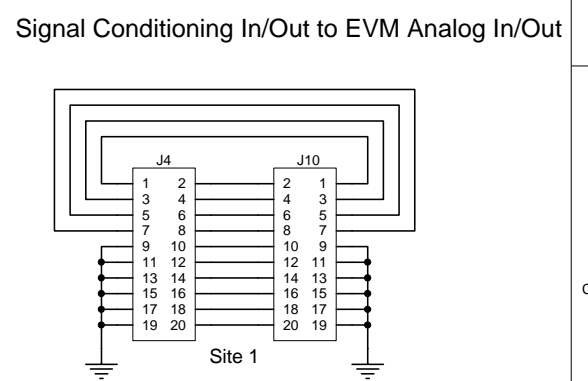
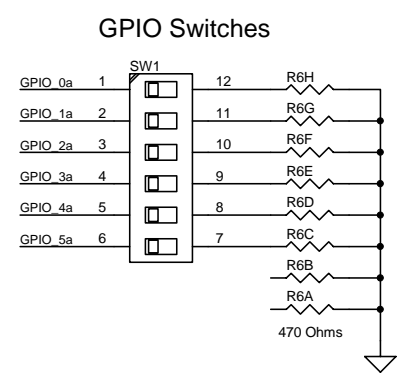
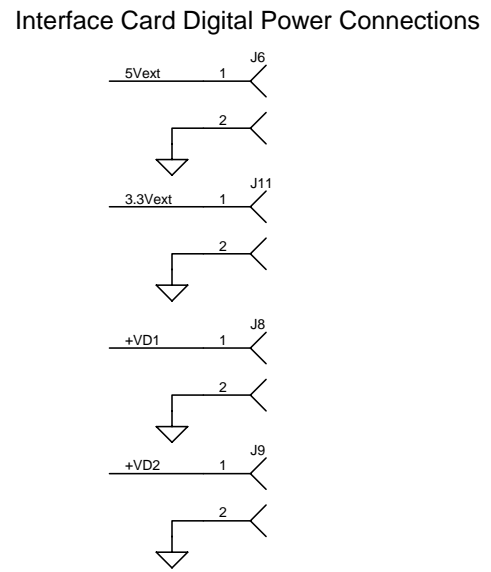
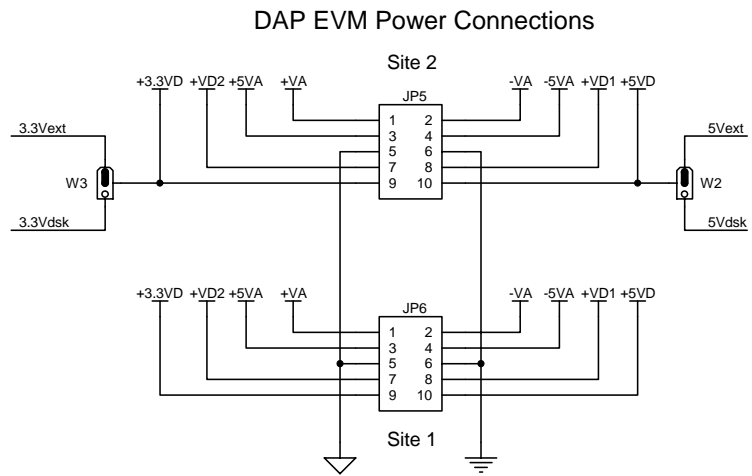

Title: 5-6K Interface Board Schematic			
Engineer: Tom Hendrick	SIZE: B	DATE: 24-May-2006	REV: B
Drawn By: Tom Hendrick	FILE: EDGE #6441282	SHEET: 2	OF: 2

6 Related Documentation from Texas Instruments

To obtain a copy of any of the following TI documents, call the Texas Instruments Literature Response Center at (800) 477-8924 or the Product Information Center (PIC) at (972) 644-5580. When ordering, please identify this booklet by its title and literature number. Updated documents can also be obtained through our website at www.ti.com.

Data Sheets:

TMS320 Cross-Platform Daughtercard Specification
SN74CBT3257, 4-Bit 1-Of-2 FET Multiplexer/Demultiplexer
SN74AHC1G04, Single Inverter Gate
SN74AHC1G32, Single 2-Input Positive-OR Gate
Designing Modular EVMs for Data Acquisition Products

Literature Number:

[SPRA711](#)
[SCDS017](#)
[SCLS318](#)
[SCLS317](#)
[SLAA185](#)

7 5-6K Interface Board Assembly and Schematics

The board assembly and schematics are attached on the following pages.

EVALUATION BOARD/KIT IMPORTANT NOTICE

Texas Instruments (TI) provides the enclosed product(s) under the following conditions:

This evaluation board/kit is intended for use for **ENGINEERING DEVELOPMENT, DEMONSTRATION, OR EVALUATION PURPOSES ONLY** and is not considered by TI to be a finished end-product fit for general consumer use. Persons handling the product(s) must have electronics training and observe good engineering practice standards. As such, the goods being provided are not intended to be complete in terms of required design-, marketing-, and/or manufacturing-related protective considerations, including product safety and environmental measures typically found in end products that incorporate such semiconductor components or circuit boards. This evaluation board/kit does not fall within the scope of the European Union directives regarding electromagnetic compatibility, restricted substances (RoHS), recycling (WEEE), FCC, CE or UL, and therefore may not meet the technical requirements of these directives or other related directives.

Should this evaluation board/kit not meet the specifications indicated in the User's Guide, the board/kit may be returned within 30 days from the date of delivery for a full refund. **THE FOREGOING WARRANTY IS THE EXCLUSIVE WARRANTY MADE BY SELLER TO BUYER AND IS IN LIEU OF ALL OTHER WARRANTIES, EXPRESSED, IMPLIED, OR STATUTORY, INCLUDING ANY WARRANTY OF MERCHANTABILITY OR FITNESS FOR ANY PARTICULAR PURPOSE.**

The user assumes all responsibility and liability for proper and safe handling of the goods. Further, the user indemnifies TI from all claims arising from the handling or use of the goods. Due to the open construction of the product, it is the user's responsibility to take any and all appropriate precautions with regard to electrostatic discharge.

EXCEPT TO THE EXTENT OF THE INDEMNITY SET FORTH ABOVE, NEITHER PARTY SHALL BE LIABLE TO THE OTHER FOR ANY INDIRECT, SPECIAL, INCIDENTAL, OR CONSEQUENTIAL DAMAGES.

TI currently deals with a variety of customers for products, and therefore our arrangement with the user **is not exclusive.**

TI assumes no liability for applications assistance, customer product design, software performance, or infringement of patents or services described herein.

Please read the User's Guide and, specifically, the Warnings and Restrictions notice in the User's Guide prior to handling the product. This notice contains important safety information about temperatures and voltages. For additional information on TI's environmental and/or safety programs, please contact the TI application engineer or visit www.ti.com/esh.

No license is granted under any patent right or other intellectual property right of TI covering or relating to any machine, process, or combination in which such TI products or services might be or are used.

FCC Warning

This evaluation board/kit is intended for use for **ENGINEERING DEVELOPMENT, DEMONSTRATION, OR EVALUATION PURPOSES ONLY** and is not considered by TI to be a finished end-product fit for general consumer use. It generates, uses, and can radiate radio frequency energy and has not been tested for compliance with the limits of computing devices pursuant to part 15 of FCC rules, which are designed to provide reasonable protection against radio frequency interference. Operation of this equipment in other environments may cause interference with radio communications, in which case the user at his own expense will be required to take whatever measures may be required to correct this interference.

Mailing Address: Texas Instruments, Post Office Box 655303, Dallas, Texas 75265
Copyright © 2006, Texas Instruments Incorporated

EVM WARNINGS AND RESTRICTIONS

It is important to operate this EVM within the input voltage range of -15 V to +15 V and the output voltage range of -15 V to +15 V.

Exceeding the specified input range may cause unexpected operation and/or irreversible damage to the EVM. If there are questions concerning the input range, please contact a TI field representative prior to connecting the input power.

Applying loads outside of the specified output range may result in unintended operation and/or possible permanent damage to the EVM. Please consult the EVM User's Guide prior to connecting any load to the EVM output. If there is uncertainty as to the load specification, please contact a TI field representative.

During normal operation, some circuit components may have case temperatures greater than 23°C. The EVM is designed to operate properly with certain components above 40°C as long as the input and output ranges are maintained. These components include but are not limited to linear regulators, switching transistors, pass transistors, and current sense resistors. These types of devices can be identified using the EVM schematic located in the EVM User's Guide. When placing measurement probes near these devices during operation, please be aware that these devices may be very warm to the touch.

Mailing Address: Texas Instruments, Post Office Box 655303, Dallas, Texas 75265
Copyright © 2006, Texas Instruments Incorporated

IMPORTANT NOTICE

Texas Instruments Incorporated and its subsidiaries (TI) reserve the right to make corrections, modifications, enhancements, improvements, and other changes to its products and services at any time and to discontinue any product or service without notice. Customers should obtain the latest relevant information before placing orders and should verify that such information is current and complete. All products are sold subject to TI's terms and conditions of sale supplied at the time of order acknowledgment.

TI warrants performance of its hardware products to the specifications applicable at the time of sale in accordance with TI's standard warranty. Testing and other quality control techniques are used to the extent TI deems necessary to support this warranty. Except where mandated by government requirements, testing of all parameters of each product is not necessarily performed.

TI assumes no liability for applications assistance or customer product design. Customers are responsible for their products and applications using TI components. To minimize the risks associated with customer products and applications, customers should provide adequate design and operating safeguards.

TI does not warrant or represent that any license, either express or implied, is granted under any TI patent right, copyright, mask work right, or other TI intellectual property right relating to any combination, machine, or process in which TI products or services are used. Information published by TI regarding third-party products or services does not constitute a license from TI to use such products or services or a warranty or endorsement thereof. Use of such information may require a license from a third party under the patents or other intellectual property of the third party, or a license from TI under the patents or other intellectual property of TI.

Reproduction of information in TI data books or data sheets is permissible only if reproduction is without alteration and is accompanied by all associated warranties, conditions, limitations, and notices. Reproduction of this information with alteration is an unfair and deceptive business practice. TI is not responsible or liable for such altered documentation.

Resale of TI products or services with statements different from or beyond the parameters stated by TI for that product or service voids all express and any implied warranties for the associated TI product or service and is an unfair and deceptive business practice. TI is not responsible or liable for any such statements.

TI products are not authorized for use in safety-critical applications (such as life support) where a failure of the TI product would reasonably be expected to cause severe personal injury or death, unless officers of the parties have executed an agreement specifically governing such use. Buyers represent that they have all necessary expertise in the safety and regulatory ramifications of their applications, and acknowledge and agree that they are solely responsible for all legal, regulatory and safety-related requirements concerning their products and any use of TI products in such safety-critical applications, notwithstanding any applications-related information or support that may be provided by TI. Further, Buyers must fully indemnify TI and its representatives against any damages arising out of the use of TI products in such safety-critical applications.

TI products are neither designed nor intended for use in military/aerospace applications or environments unless the TI products are specifically designated by TI as military-grade or "enhanced plastic." Only products designated by TI as military-grade meet military specifications. Buyers acknowledge and agree that any such use of TI products which TI has not designated as military-grade is solely at the Buyer's risk, and that they are solely responsible for compliance with all legal and regulatory requirements in connection with such use.

TI products are neither designed nor intended for use in automotive applications or environments unless the specific TI products are designated by TI as compliant with ISO/TS 16949 requirements. Buyers acknowledge and agree that, if they use any non-designated products in automotive applications, TI will not be responsible for any failure to meet such requirements.

Following are URLs where you can obtain information on other Texas Instruments products and application solutions:

Products		Applications	
Amplifiers	amplifier.ti.com	Audio	www.ti.com/audio
Data Converters	dataconverter.ti.com	Automotive	www.ti.com/automotive
DSP	dsp.ti.com	Broadband	www.ti.com/broadband
Interface	interface.ti.com	Digital Control	www.ti.com/digitalcontrol
Logic	logic.ti.com	Military	www.ti.com/military
Power Mgmt	power.ti.com	Optical Networking	www.ti.com/opticalnetwork
Microcontrollers	microcontroller.ti.com	Security	www.ti.com/security
RFID	www.ti-rfid.com	Telephony	www.ti.com/telephony
Low Power Wireless	www.ti.com/lpw	Video & Imaging	www.ti.com/video
		Wireless	www.ti.com/wireless

Mailing Address: Texas Instruments, Post Office Box 655303, Dallas, Texas 75265
Copyright © 2007, Texas Instruments Incorporated